



NIGHT VISION MONOCULAR
PHANTOM 20

In USA: 2331 Superior Ave. Cleveland, OH 44114
In Canada: 105 Sparks Ave., Toronto, ON M2H 2S5

IMPORTANT INFORMATION

Read prior to activation

You have just purchased a complicated electronic device. To operate it properly, please read this manual carefully. Here are some common Precautions that must be noted.

- **NEVER** expose the opened objective lens of an active unit in daylight. At daytime objective lens must be covered by caps. There is a tiny hole in the cap to provide enough light for daytime operation. It is allowed to turn on the unit at daytime, but caps must cover the lenses.
- **NEVER** aim active unit at intense light sources (i.e. lights, headlamps, campfires, the moon, etc.)
- **NEVER** reverse the polarity of a battery
- **NEVER** disassemble the unit
- **NEVER** connect the unit to external power sources
- **ALWAYS** remove batteries when not in use for a long period
- **ALWAYS** keep the objective lenses covered when not in use
- **ALWAYS** store in a warm dry place when not in use

ATTENTION!

Image quality of the object, which is being observed when an image intensifier is functioning, depends mainly upon operating characters of this image intensifier.

Due to this fact black spots, which are inherent in the image intensifier, may be seen in the field of view of a viewing device. Field of view is shown below.

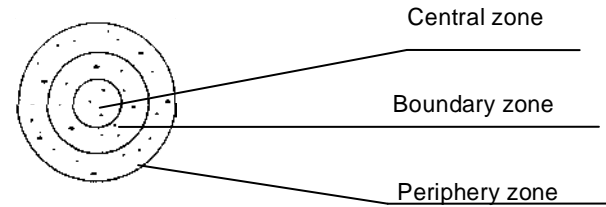

Permissible defects, which may be seen in the field of viewing device, are given in the table

Type of black spots	Zone	Size of black spots, mm	Number of spots
Immovable	Central (circle of diameter 5.5 mm)	Up to 0.073 From 0.073 to 0.150 From 0.150 to 0.294	Not limited 5 1
	Boundary (circle of diameter 5.5-9.0 mm)	From 0.073 to 0.150 From 0.150 to 0.294 From 0.294 to 0.400	10 3 1
	Periphery (circle of diameter 9.0-11.0 mm)	Not limited	Not limited
Moving	Entire field (circle of diameter 11.0 mm)	From 0.150 to 0.294	1

9. ACCEPTANCE CERTIFICATE

NIGHT VISION DEVICE PHANTOM 20

Serial Number _____

Corresponds to technical conditions ADSH 3.807.020 TU and is admitted for use.

Date of production - _____

Place for seal

Quality inspector _____

(Signature)

CONTENTS

- 1. Overview
 - i) Application and Features of Phantom 20
 - ii) Warning
 - iii) Precautions
- 2. Components
- 3. Specifications
- 4. Construction
- 5. Operating Instructions
 - 5.1 Pre-starting procedures
 - 5.2 Testing of operation
 - 5.3 Operation at night
 - 5.4 Using interchangeable lenses
 - 5.5 Using the camera / video adapter
- 6. Troubleshooting
- 7. Warranty
- 8. Customer support
- 9. Acceptance Certificate

THANK YOU FOR PURCHASING PHANTOM 20 NIGHT VISION DEVICE. PLEASE DEMAND TO CHECK THE DEVICE FOR PROPER OPERATION WHEN BUYING IT. PLEASE READ ALL THE INSTRUCTIONS CAREFULLY BEFORE USING.

1. OVERVIEW

Phantom 20 Night Vision monocular is a sophisticated optico-electronic observation device designed to allow observations of personnel and orientation in nighttime conditions. The unit is utilizing an image intensifier, which amplifies available moonlight, starlight or man-made light. Waterproof, lightweight and compact - this advanced system is one of the most affordable systems on the market.

Some of the typical activities where the Phantom 20 will be useful: boating, search and rescue, law enforcement, wildlife observation, security.

Features

- Camera - video adaptable
- Totally waterproof construction.
- Rugged body.
- High quality wide-angle interchangeable lens (m 42x1).
- The built in infra red illuminator allows observations in total darkness (i.e. basement or cave);
- The internal lens with focusing mechanism ensures adjustment for sharpness for both near and remote objects;
- The eye piece allows Dyoptric adjustment for the eyes of the viewer;
- Soft rubber eye-cap protects from the disturbing lateral light and occasional impacts, thus making surveillance more comfortable;

THE SOLE OBLIGATION OF NEWCON UNDER THIS LIMITED WARRANTY SHALL BE TO REPAIR OR REPLACE THE COVERED PRODUCT, IN ACCORDANCE WITH THE TERMS SET FORTH HEREIN.

NEWCON EXPRESSLY DISCLAIMS ANY LOST PROFITS, GENERAL, AND SPECIAL, INDIRECT OR CONSEQUENTIAL DAMAGES WHICH MAY RESULT FROM BREACH OF ANY WARRANTY, OR ARISING OUT OF THE USE OR INABILITY TO USE ANY NEWCON PRODUCT.

8. CUSTOMER SUPPORT

Should you experience any difficulties with your Newcon OPTIK product, consult the enclosed manual. If the problem remains unresolved, contact our customer support department at (416) 663-6963. Our operating hours are 9am-5pm, Monday - Friday, standard East time.

At no time should equipment be sent back to Newcon without following the instructions of our technical support department. Newcon accepts no responsibility for unauthorized returns.

To locate NEWCON Authorized Dealer call:

Tel: (416) 663-6963 Fax: (416) 663-9065

Email: newconsales@newcon-optik.com

Web: www.newcon-optik.com

The defective products should be shipped to:

From USA only: 2331 Superior Ave. Cleveland, OH 44114

From all other countries: 105 Sparks Ave., Toronto, ON M2H 2S5, CANADA

7. WARRANTY

NEWCON OPTIK warrants this product against defects in material and workmanship for one year from the date of the original date of consumer's purchase, but no more than 18 months from the date of delivery being indicated and stamped on the acceptance certificate purchase. Should your NEWCON product prove defective during this period, please bring the product securely packaged in its original container or an equivalent, along with proof of the date of original purchase, to your NEWCON Dealer. NEWCON will, repair (or at its option replace), the product or part thereof, which, on inspection by NEWCON, is found to be defective in materials or workmanship.

What This Warranty Does Not Cover:

NEWCON is not responsible for warranty service should the product fail to be properly maintained or fail to function properly as a result of misuse, abuse, improper installation, neglect, damage caused by disasters such as fire, flood, and lightning, improper electrical current, or service other than by a NEWCON Authorized Service. Postage, insurance, or shipping costs incurred in presenting your NEWCON product for warranty service are your responsibility. Please include a cheque or money order made out to NEWCON OPTIK for the amount of US\$10.00 to cover shipping and handling. NEWCON OPTIK may replace any product that has been discontinued or is out of stock, by another current product of comparable value and function.

NEWCON OPTIK DISCLAIMS ANY WARRANTIES, EXPRESS OR IMPLIED, WHETHER OF MERCHANTABILITY OR FITNESS FOR A PARTICULAR USE, EXCEPT AS EXPRESSLY SET FORTH HEREIN.

- Standard and commonly available batteries ensure operation of the device of no less than 10 hours;
- Two switch buttons ensure separate switching of the night vision device and the IR LED illuminator, thus providing economic use of batteries' power;
- Original compact design and ergonomic shape make the device handy and comfortable to hold with one hand
- Low battery indicator
- Delayed shot off ensures automatic shot off to prevent battery drain

Warning!

After transportation or keeping the device at temperature lower than -25°C (-13°F), the device must be warmed up to ambient temperature, from -20°C (-4°F) to +40°C (104°F) during 2-3 hours.

Precaution

Phantom 20 is a precision optical instrument equipped with electronics.

Therefore, it should be handled with due care.

- Keep your device away from direct sunlight, impacts, dust, moisture, and sudden changes of temperatures.
- Do not touch the optical surfaces with fingers. Doing so may damage the anti-reflection coating.
- Cleaning of optical surfaces is possible only with professional camera lens cleaning supplies.
- To clean the exterior of the device, use only a soft clean cloth.
- Do not take the cover off the lens if not necessary.

- Keep away from heating appliances and central heating.
- Make sure to switch off the unit during periods of non-operation and when storing the device for long period of time.
- Do not apply superfluous efforts at work with lens assembly, agile elements and thread connections.
- Due to considerable optical magnification of the eye-piece some small structures inside the tube coating in the form of dark and/or white points may be seen in the field of view which does not affect the serviceability of the device;
- The resolving power (resolution) may change in the direction from the center towards the perimeter of the field of view. This is an inherent feature of the image tube type utilized in the device. We would recommend placing the scene of observation in the center of the field of view.
- Make sure to remove the battery during periods of non-operating and when storing the device for long period of time.

2. COMPONENTS

Phantom 20 is supplied with the following components:

NAME	QUANT.
Phantom 20	1
Carrying strap	1
Case	1
Lenses (85/1.5, 300/4.5, 500/5.6, 1000/10) (optional)	4
Camera/video adapter (optional)	1
Lens cover	1
Manual	1
Warranty Registration Card	1

6. TROUBLESHOOTING

The monocular does not work.

Check that the battery is installed properly.

Check the charge of the batteries.

Replace if it is weak.

The image does not appear in focus.

Bring the inspected object to the center of the image. Turning the eyepiece focusing lever (3) adjust to achieve the clearest image on the screen. Then obtain the most clear-cut image of the object

The image doesn't appear in focus. Bring the inspected object, if the view still does not seem in focus, clean the lenses; they could be foggy or dusty.

Unit flashes

It is normal for the unit to flash within the first 2 minutes of activation. If the flashing continues afterwards the following is a possible cause: bright environment (even with the cap closed!)

Condensation accumulates on the parts.

It is O.K. to use the monocular in cold. However, when the unit is brought from the cold into a warm environment, it has to warm up for up to 5 hours (not minutes!). Only then it is allowed to turn it ON again.

Visibility decreases and / or disappears.

Bright light sources (moon, projectors or headlights) may cause visibility to degrade or even completely disappear. Move the scope away from the light source immediately. The image should be restored in within 2 minutes.

Poor atmospheric conditions such as fog, haze or extremely dark environments, will decrease the visibility distance of the unit.

AT INSUFFICIENT AMBIENT ILLUMINATION

Activate switch (4) for switching on the device. Press button (5) for switching on IR illuminator. Direct the device on the object to be viewed.

Note: The I/R turns off, if not being pressed on.

5.4. Using interchangeable lenses.

The unit is equipped with PENTAX “screw type” removable lens F 50/1.2, M 42x1. It will accept most Pentax screw type lenses, or using proper adapters, many other lenses.

Note: When screwing back the original lens, make sure to insert the lens all the way, to prevent humidity penetration

5.5. Using the camera/video adapter.



Before using the adapter, remove carefully the rubber eyepiece.

The adapter consists of 2 rings:

- a) Camera adapter is 52x1 mm size. It will go into the filter thread of lenses for many cameras, like Nikon etc.
- b) Video adapter is 37 x 1mm. It will fit most Sony cameras and some other as well. If not, check with local camera store and/or camera manufacturer for proper step up/step down rings.

3. SPECIFICATIONS of Phantom 20

Generation	1
Magnification, X.	2.3 ± 0.2
Field of View, angle. degrees, not less.....	16°
Focus Range, m.....	1 - ∞
Objective focal length, mm..	50, M42x1
Objective F number	1,2
Eye Relief, mm	25
Eyepiece focal length, mm	15
System Resolution, mrad	1
Dioptic correction	± 5
Camera/video adapter connecting size, mm... ..	52x1/37x1
Power Supply	3V Lithium CR2
Battery life, hours:	
Without I/R	25
With I/R	10
Allowed illumination, lx5-10 ⁻³ - 1x10 ⁻¹
Allowed external temperature, °C	-25 ÷ +40
Dimensions, inches	7.3x3.3x2, 6
Dimensions, mm	185x85x65
Weight, just viewer	18oz; 0.535 kg
Gross Shipp. Weight	28 oz; 0,8 kg

NOTE: As the design is being continuously improved some descriptions may differ from those given above.

4. CONSTRUCTION

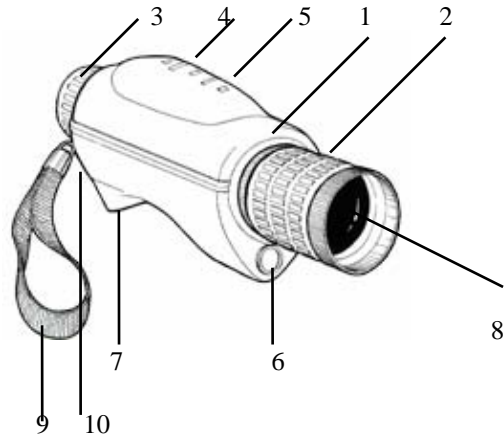

- 1- Body
- 2- Lens Focusing Ring
- 3- Eyepiece
- 4- Switch Button for the Scope
- 5- IR Illuminator Switch
- 6- IR Illuminator
- 7- Battery House Cover
- 8- Lens Cover
- 9- Carrying Strap
- 10- Low battery indicator

5. OPERATION INSTRUCTIONS

WARNING!

**NEVER OPERATE YOUR NIGHT VISION DEVICE IN DAYLIGHT AREAS WITHOUT THE LENS COVER ON!
NEVER DIRECT THE LENS IN THE DIRECTION OF BRIGHT LIGHT!**

5.1 Pre-starting procedures.

1. Unpack the device. In order to replace the battery unscrew battery house cover (7) and replace the battery observing the polarity indicated; close cover (7). First, make sure the lens cap (8) is closed: Check the functioning of the device by switching it on (click switch 4) and looking through eye-piece (3). If power supply and the battery is O.K., you will see greenish-lit screen. If the screen is not lit, check the battery. Replace the battery if necessary. If everything works, now is a great time to fill the warranty card. You can find the unit's serial number on the button.

5.2. Testing of operation

Turn on the device-using switch (4). Lens cap (8) must be on. Direct the device on an object placed within 40-50 m from the viewer. Turning the eye-piece (3) try to achieve the sharpest image on the screen of the image tube. For close focusing rotate the front lens (2)

5.3.Operation at night

AT MOON LIGHT: Unscrew the lens cover (8). Turn on the device-using switch (4). Turning the eyepiece focusing lever (3) adjust to achieve the most clear image on the screen. Then obtain the most clear-cut image of the object focusing with ring,(2). Repeat the steps of focusing if necessary.

Note: The ON button is equipped with automatic shut off circuitry. After a while, it will shut itself off, to prevent battery drain.