



Operation Manual



LAM 2 IR

INFRARED LASER AIMER / ILLUMINATOR

105 Sparks Ave., Toronto, ON M2H 2S5, Canada

IMPORTANT INFORMATION

Read prior to activation

You have just purchased a sophisticated electronic device. To operate it properly, please read this manual carefully. The unit belongs to Class IIIb laser products in accordance with IEC 60825-1. It is potentially hazardous for your vision. Here are some general precautions that must be observed.

Avoid any exposure of the eye to direct or reflected laser beam. Naked skin exposure to laser beam is not recommended.

- **NEVER** subject the unit to excessive impacts
- **NEVER** transport the unit without its case
- **NEVER** disassemble the unit
- **NEVER** reverse polarity of the battery
- **ALWAYS** make sure that the device is fixed firmly on the weapon
- **ALWAYS** turn the device off when it is not in use
- **ALWAYS** remove battery when not in use for a long period
- **ALWAYS** store the unit in a warm dry place when not in use
- **ALWAYS** clean output windows with soft cloth only
- **ALWAYS** check the O-ring when replacing the battery.

TABLE OF CONTENTS

1.	BRIEF DESCRIPTION	2
2.	UNIT DESIGN AND APPEARANCE	3
3.	DELIVERY SET	8
3.1	Standard delivery set.....	8
3.2	Optional accessories.....	8
4.	SPECIFICATIONS	10
5.	OPERATION INSTRUCTIONS.....	11
5.1	Inserting battery	11
5.2	Mounting the unit on a weapon.....	11
5.3	Adjusting the unit on a weapon.....	12
5.4	Aiming	14
5.5	Preparing the unit for transportation	14
6.	Care, storage and transportation	15
6.1	General.....	15
6.2	Long-term storage	16
6.3	Transportation.....	17
7.	TROUBLESHOOTING	18
8.	WARRANTY	19
9.	CUSTOMER SUPPORT.....	20
8.	QUALITY CERTIFICATE.....	21

1. BRIEF DESCRIPTION

LAM 2 IR laser aimer / illuminator (the unit) is designed for precise aiming at night. Attached to a weapon equipped with Picatinny rail MIL-STD-1913 it forms an IR laser beam spot on the target and provides IR illumination.

Laser beam, created by a semiconductor laser diode, is invisible to the naked eye, while it is perfectly visible through night vision goggles, rifle sights or hand-held devices.

Laser beam (wavelength of 830–850 nm) emitted by the unit is potentially dangerous for eyes. The unit belongs to laser safety Class IIIb according to IEC 60825-1 classification.

**INVISIBLE LASER RADIATION CLASS IIIb -
DO NOT LOOK INTO THE BEAM.
CAREFULLY READ ALL THE INSTRUCTIONS
PRIOR TO USE.
FAILURE TO OBEY THE INSTRUCTIONS
WILL VOID THE WARRANTY.**

2. UNIT DESIGN AND APPEARANCE

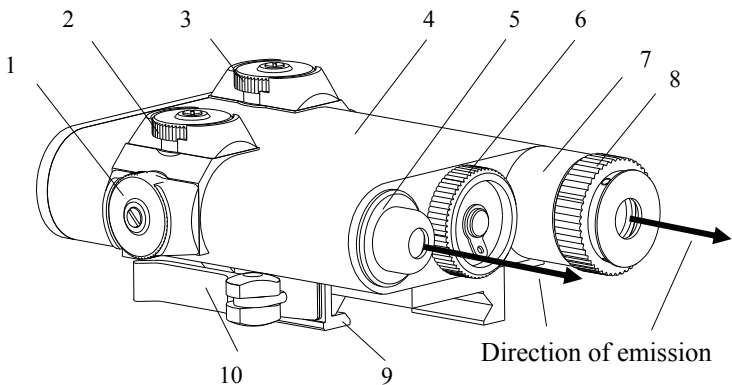

Fig. 1 — LAM 2 IR front view

- 1 - windage adjustment knob, aimer channel
- 2 - elevation adjustment knob, aimer channel
- 3 - elevation adjustment knob, illuminator channel
- 4 - housing
- 5 - aimer
- 6 - battery compartment cover
- 7 - illuminator
- 8 - illuminator divergence adjustment ring
- 9 - bracket
- 10 - throw lever mount

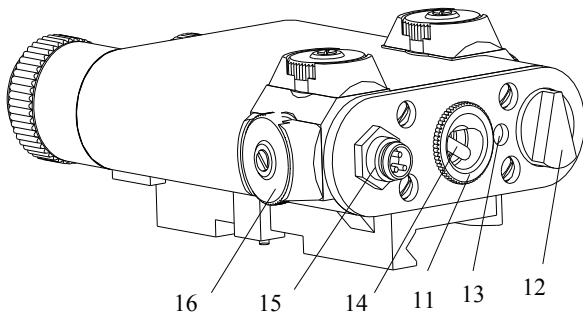

Fig. 2 — LAM 2 IR rear view

- 11 - blocking ring
- 12 - mode switch
- 13 - low battery indicator
- 14 - power switch
- 15 - remote button connector
- 16 - windage adjustment knob, illuminator channel

The unit consists of two laser emitters – aimer (5, Fig. 1) and illuminator (7, Fig. 1) – combined in one housing (4, Fig. 1) with interaxis distance of 44.8 millimeters. The unit is powered by a lithium battery (CR123 type). Battery is installed between aimer and illuminator and covered with battery compartment cover (6) attached to the housing.

The junction of battery compartment cover (6, Fig. 1) and housing (4, Fig. 1) is sealed with rubber O-ring.

Throw lever mount (10) fixes the unit on a weapon (Picatinny rail MIL-STD-1913).

Beam divergence can be changed in between 3 and 105 mrad (0.2°-6°) by turning the grooved adjustment ring (8, Fig. 1).

Operating modes switch (12) has the following positions:

- OFF** unit is off
- A** aimer is on, illuminator is off
- I** illuminator is on, aimer is off
- D** Both illuminator and aimer are on
- BT** battery test

In **BT** mode the LED (13, Fig. 2) indicates battery level: solid red LED means the battery charge is normal, if it is blinking - the battery must be replaced.

The unit can operate at high and low power levels of laser. An appropriate level can be chosen with switch (14, Fig. 2).

To prevent unintentional switching to high power mode, switch (14, Fig. 2) is blocked with the ring (11, Fig. 2). To unblock the switch and allow high power mode (H) the ring must be pulled out and turned.

High power mode is a health hazard!

Lock switch (14) with blocking ring (11) when you do not intend using the unit in high power mode.

The unit can be turned on either with a switch (12, Fig. 2) or with a remote control pressure switch, when it is connected through the remote control connector (15, Fig. 2). When the remote button is connected, switch (14, Fig. 2) only pre-selects modes, but does not activate them; the unit only goes on in selected mode while the remote button is pressed. Connector (15, Fig. 2) should be covered with the cap when it is not used. The remote button can be attached to a rifle pivot or grip with provided Velcro tape.

The unit has independent windage / elevation adjustment mechanisms for aimer and illuminator channels. Knobs (1, Fig. 1) and (2, Fig. 1) adjust aimer channel, while knobs (3, Fig. 1) and (16, Fig. 2) adjust illuminator channel. Rotation of the adjustment knobs moves radiation spots on the target. Directions of adjustment are marked on the knobs with **UP** (beam moves up) and **R** (beam moves right).

When shooting with the unit, keep in mind that the ballistic trajectory is a complicated curve, while laser beam is a straight

line, and these two lines cross in one or two points (depending on the location of the unit on the weapon).

For precise shooting you should know the distance to the target and have trajectory correction table for your weapon. The shooter should estimate the distance and determine the shift of the aimer spot in accordance with the correction table.

Use illuminator when light conditions do not allow seeing the target in night vision goggles, rifle scope or monocular.

There is no need to adjust the unit each time it is remounted on the same Picatinny rail.

An optional optical add-on diffuser attached to the illuminator channel widens the beam up to 180 degrees.

Optional pattern generators (caps) shape the beam into patterns leaving beam divergence intact. These generators help recognize the operator in tactical engagement. The caps are attached on the illuminator angle adjustment ring with additional rubber gasket (Fig. 3).

3. DELIVERY SET

Standard delivery set

	Quantity
Laser aimer / illuminator LAM 2 IR with mount	1
Remote pressure switch	1
O-Ring	1
Soft case	1
Manual	1
Warranty card	1

Optional accessories

Optical add-on diffuser and various pattern generators may be added on a special order.

The unit can be supplied with laser light diffuser and various pattern generators, which modify the illuminator laser beam. These devices look like grooved caps that cover the illuminator output window. The diffuser extends the spatial angle of the beam by 4 times. The pattern generators do not impact the beam divergence, but they form a special predefined pattern, which helps to recognize the operator in tactical engagement.

The caps are fixed on the illuminator angle adjustment ring by means of additional rubber gasket (Fig. 3). This construction,

being very simple in design and usage, enables illuminator beam adjustment in the same way as if nothing is attached to the illuminator output.

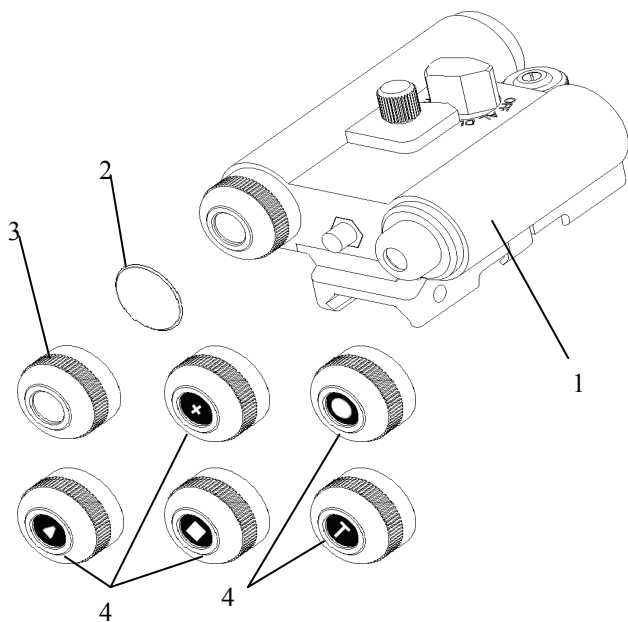

1 - LAM 2 IR; 2 - rubber gasket;
3 - diffuser; 4 - various pattern generators

Fig. 3 Optional accessories

4. SPECIFICATIONS

	Aimer	Illuminator
Laser wavelength	845 ± 15 nm	845 ± 15 nm
Beam divergence	0.3 mrad (1')	1..105 mrad (3.4'...6°)
Spot size at 100 meters	30 mm	0.1-10.5 m
Power of laser emission, L mode H mode	<1 mW >20 mW	<2 mW >25 mW
Windage / elevation adjustment range	± 20 mrad (±1°10')	
Adjustment step	0.5±0.05 mrad (50mm @100m)	0.4±0.04 mrad (40mm @100m)
Adjustment accuracy after 1000 shots	0.5 mrad	
Adjustment accuracy after 100 installations on the rail	1 mrad	
Battery type	3V Lithium CR 123	
Operating temperature range	-40°C ..+60°C	
Storage conditions, temperature range relative humidity	-40°C .. +60°C up to 55% at 25°C	
Dimensions	122x81x41 mm	
Weight	300 g	

5. OPERATION INSTRUCTIONS

DANGER! THIS LASER EQUIPMENT IS HAZARDOUS FOR YOUR EYES!

- **Do not look into laser beam with naked eyes or through any optical device.**
- **Do not point an active unit at highly reflective surfaces or towards other individuals or animals.**

Inserting battery

- Ensure the mode switch (12, Fig. 2) is in OFF position.
- Unscrew battery compartment cover (6, Fig. 1) and insert the battery observing the polarity marked on the body. Screw back the cap (6, Fig. 1) tightly.

When installing battery pay attention to the O-ring condition. It should have no visible defects to ensure waterproofing ability.

Mounting the unit on a weapon

- Mount the unit on Picatinny rail using throw lever mount (10, Fig. 1) so that the laser emission is directed towards the target;
- If desired, connect the remote switch cable to the connector (15, Fig. 2) and tighten the nut. Fix the remote switch on the

weapon pivot or grip by Velcro tape in the place, convenient for pressing the key. Trim the tape if necessary.

Adjusting the unit on a weapon

The unit can be adjusted on a weapon using two techniques:

- with laser bore sight and bore sight target;
- with regular weapon sight and special target.

In both cases you will need a night vision device, a bore sight target and a gun rest (or its substitute).

If the weapon is bore sighted using field means (sandbags, rucksacks) and the weapon is laid on its side for stability, turn the bore sight too.

Prior to adjusting the unit, which has never been in operation, carry out 10 shots to stabilize the adjustment mechanisms under the influence of recoil.

Adjusting with help of laser bore sight

1. Mount the unit on the weapon.
2. Fix the weapon in the aiming rest.
3. Insert the laser bore sight into the barrel.
4. Zero the bore sight in accordance with its operation manual.
5. Set the target at the distance, required for this weapon and this target.
6. Remove protective cap from aimer (5, Fig. 1).
7. Activate the unit in DL or DH mode.

8. Set minimal divergence of the illuminator channel.
9. Set laser bore sight on the aiming mark on the target.
10. Superpose centers of the spots produced by the aimer and illuminator on the aiming mark by rotating adjustment knobs (1, Fig. 1), (2, Fig. 1), (3, Fig. 1), (16, Fig. 2).
11. Check again that all three spots (laser bore sight mark, aimer mark and center of the illuminator mark) are on the correct aiming point on the target.
12. Turn the unit off.

Adjusting with regular weapon sight

1. Mount the unit on the weapon.
2. Fix the weapon in the aiming rest and aim it by means of an iron sight at the aiming mark on the target.
3. Remove the protective cap from aimer (5, Fig. 1).
4. Activate the unit in DL or DH mode.
5. Set the minimal divergence of the illuminator channel.
6. Superpose centers of the spots produced by the aimer and illuminator on the aiming mark by rotating adjustment knobs (1, Fig. 1), (2, Fig. 1), (3, Fig. 1), (16, Fig. 2).
7. Fire the weapon
8. If point of impact is off the aiming mark adjust windage and elevation by rotating adjustment knobs (1, Fig. 1), (2, Fig. 1), (3, Fig. 1), (16, Fig. 2). (Each click of adjustment

mechanisms shifts radiation spot by 5 cm on the target at 100 m.)

9. Repeat steps 7 and 8 until point of impact coincides with the aiming mark.
10. Cover the aimer (5, Fig. 1) with protective cap.

When adjusted unit is remounted on the same Picatinny rail of the same weapon no re-adjustment is required.

Aiming

When firing at a distance of up to 200 m the radiation spot is to be aimed at the target.

When firing at a longer distance elevation adjustment may be required.

Preparing the unit for transportation

1. Turn the unit off by turning operating modes switch (12, Fig. 2) to AV position.
2. Cover aimer (5, Fig. 1) with protective cap.
3. Disconnect the remote switch from the weapon.
4. Loosen throw lever (10, Fig. 1), remove the unit from Picatinny rail.
5. Pack the unit and remote switch into the case.

6. Care, storage and transportation

General

The unit is a sophisticated precise optical instrument equipped with electronics. Therefore, it should be handled with due care.

- Never disassemble the unit.
- Keep away from direct sunlight, impacts, dust, moisture, and sharp changes of temperature.
- Do not keep the unit at temperatures higher than 70°C (158°F). Keep away from heating appliances and central heating.
- Do not touch the optical surfaces with fingers. Doing so may damage the anti-reflection coating.
- Avoid shocks and sharp jolts.
- Clean optical surfaces only with professional camera lens cleaning supplies.
- Use soft clean cloth to wipe the exterior of the unit.
- Remove battery when storing the unit for long period of time.
- All repairs must be performed by an authorized service.

If the unit was exposed to salt water it should be rinsed in fresh water and dried outside at no more than 55°C.

Long-term storage

1. When preparing for long-term storage, cover the external metal surfaces of the unit with protective lubricant. Each 4 (four) years old layer of lubricant should be removed and new layer applied.

To remove old layer of lubricant:

- Wipe the unit with clean dry cloth,
- Degrease metal surfaces of the unit with benzine moistened cloth,
- Dry the unit out-of-doors.

Do not touch unit's metal surfaces with fingers after cleaning.

To apply new layer of lubricant:

- Within two hours from the cleaning apply an even 0.2-0.5 mm thick layer of lubricant on metal surfaces with a brush.
 - Do not cover plastic parts.
2. When preparing for a long-term storage the unit just received from manufacturer or from workshop ensure that actual set is the same as indicated in the Delivery Set section of this manual.
 3. Cases with units should be placed on stands, shelves or in cupboards in dry heated and ventilated premises in accordance with Storage conditions as described in Specifications.

4. Units can be stored in transportation cases at temperatures up to 70°C for no more than 16 hours.
5. It is unacceptable to keep units on the floor, near stoves or windows that let through direct sun rays.
6. Presence of acid and alkaline vapor, as well as of other aggressive admixtures in the air in the storage area may cause damage to the unit.
7. After 4 years of storage, it is necessary to perform thorough inspection of units' functionality.

Transportation

When packed, the units can be transported by any covered means in accordance with Storage conditions as described in Specifications.

When in operation, the unit is to be transported in its case or mounted on a weapon.

7. TROUBLESHOOTING

The LED indicator is off when switch is ON.

Press the switch again. If the units still does not go ON check that battery is installed properly and has sufficient charge. Replace battery if necessary.

Spot shape or size has changed

Emitter objective lens is dirty. Flush emitter lens with fresh water and wipe it with soft cloth.

No radiation when activating the unit with remote switch

Turn the mode switch (12, Fig. 2) to OFF position and then turn the unit ON again. If this doesn't help, replace the remote switch.

Radiation doesn't stop when remote switch is released

Replace the remote switch.

Moisture in the battery compartment.

Check the O-ring on the battery compartment cover and replace it if necessary.

Shift of zero line when firing

Send the unit for repair.

8. WARRANTY

NEWCON warrants this product against defects in material and workmanship for one year from the date of the original purchase. Longer warranty is available, subject to the terms of the specific sales contract. Should your Newcon product prove to be defective during this period, please deliver the product securely packaged in its original container or an equivalent, along with the proof of the original purchase date, to your Newcon Dealer.

Newcon will repair (or at its option replace with the same or comparable model), the product or part thereof, which, on inspection by Newcon, is found to be defective in materials or workmanship.

What This Warranty Does Not Cover:

NEWCON is not responsible for warranty service should the product fail as a result of improper maintenance, misuse, abuse, improper installation, neglect, damage caused by disasters such as fire, flooding, lightning, improper power supply, or service other than by a NEWCON Authorized Service.

Postage, insurance, and shipping costs incurred while presenting your NEWCON product for warranty service are your responsibility.

If shipping from North America please include a cheque or money order payable to NEWCON OPTIK for the amount of \$15.00 to cover handling and return shipping.

9. CUSTOMER SUPPORT

Should you experience any difficulties with your NEWCON OPTIK product, consult the enclosed manual. If the problem remains unresolved, contact our customer support department at (416) 663-6963 or toll free at 1-877-368-6666. Our operating hours are 9am-5pm, Monday - Friday, Eastern Standard Time.

At no time should equipment be sent back to Newcon without following the instructions of our technical support department.

NEWCON OPTIK accepts no responsibility for unauthorized returns.

To locate NEWCON Authorized Dealer call:

Tel: (416) 663-6963 Fax: (416) 663-9065

Email: newconsales@newcon-optik.com

Web: www.newcon-optik.com

Defective products should be shipped to:

US Customers:

2498 Superior Ave. Cleveland, OH 44114

From all other countries:

105 Sparks Ave., Toronto, ON

M2H 2S5, CANADA

8. QUALITY CERTIFICATE

LAM 2 IR serial number _____
complies with all technical specifications and has passed the
inspection.

Date of production: _____

Quality Inspector: _____

Quality Assurance Seal

RI-2.11

NEWCON OPTIK™

Printed in Canada