



Operation Manual



LAM 10M IR 3A LASER AIMING MODULE / TARGET POINTER

105 Sparks Ave., Toronto, ON, M2H 2S5, Canada



**LASER RADIATION –AVOID
EXPOSURE TO THE BEAM
INFRARED LASER**

OUTPUT POWER <1 mW

WAVELENGTH 830-860 nm

CLASS IIIb LASER PRODUCT

**LASER WARNING LABEL IS LOCATED ON TOP
OF THE DEVICE**

IMPORTANT INFORMATION

Read prior to activation

You have just purchased a sophisticated electronic device. To operate it properly, please read this manual carefully. LAM belongs to Class IIIb laser products in accordance with IEC 60825-1.

This radiation is hazardous for your eyes. Here are some common precautions that must be observed.

Avoid any exposure of the eye to direct or closely reflected laser beam. Naked skin exposure to laser beam is not recommended.

- **ALWAYS** turn the device off when it is not in use and when you change the battery!
- **NEVER** look into the beam!
- **NEVER** subject LAM to excessive impacts
- **NEVER** transport LAM without the case
- **NEVER** disassemble LAM
- **NEVER** reverse polarity of the battery
- **ALWAYS** make sure that the device is fixed firmly on the weapon
- **ALWAYS** remove battery when not in use for a long period
- **ALWAYS** store in a warm dry place when not in use
- **ALWAYS** clean output windows with soft cloth only
- **ALWAYS** check the O-ring when replacing the battery.

CONTENTS

1.	Brief description	2
2.	Device design	3
3.	DELIVERY SET	8
3.1.	Standard delivery set.....	8
3.2.	Optional parts.....	8
4.	Specifications.....	9
5.	OPERATION INSTRUCTIONS	10
5.1.	Installing the battery	10
5.2.	Mounting LAM on a weapon.....	10
5.3.	Connecting the remote control.....	11
5.4.	Adjusting LAM on a weapon.....	11
6.	Maintenance, storage and transportation	13
6.1.	General.....	13
6.2.	Storage	14
6.3.	Transportation.....	15
7.	TROUBLESHOOTING	17
8.	WARRANTY	18
9.	CUSTOMER SUPPORT	19
10.	QUALITY CERTIFICATE	20

Carefully read all the instructions prior to use.

Failure to obey the instructions will void the warranty!

INVISIBLE LASER RADIATION

CLASS IIIb LASER PRODUCT 830–860 nm 0,9mW.

DON'T LOOK INTO THE BEAM!

1. Brief description

LAM 10M IR 3A laser aimer (hereinafter referred as LAM) is designed for precise aiming at night time. LAM forms an IR laser radiation spot on the target visible only through the night vision goggles. It can be attached to a weapon equipped with Picatinny rail MIL-STD-1913.

Laser beam, created by a semiconductor laser diode, is invisible by naked eye, while it is perfectly visible through night vision goggles, rifle sights or hand-held devices.

2. Device design

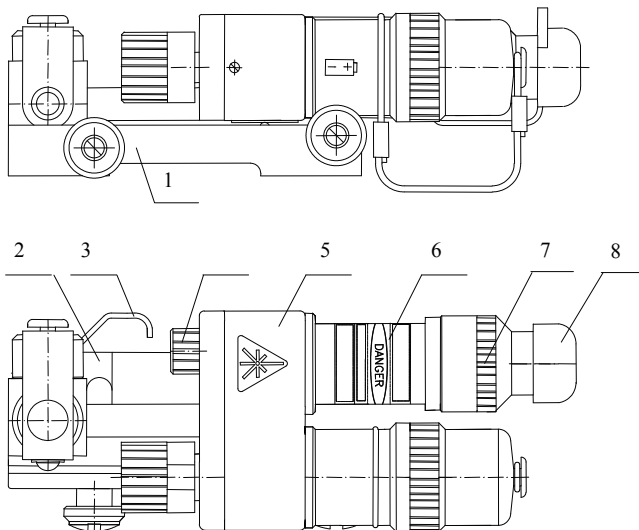

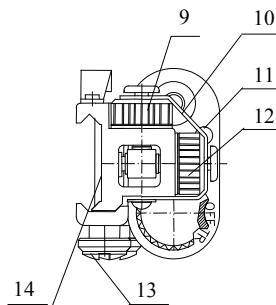

Fig. 1. LAM 10M IR 3A

- | | |
|-----------------------------------|----------------------------|
| 1 – clamp | 2 – bracket |
| 3 – stopper | 4 – remote connector |
| 5 – body | 6 – emitter |
| 7 – emitter cap | 8 – emitter protective cap |
| 9 – windage adjustment | 10 – fastener |
| 11 – ‘laser on’ warning indicator | 12 – elevation adjustment |
| 13 – fixation screw cap | 14 – fixation screw |
| 15 – battery compartment cap | 16 – battery compartment |
| 17 – operating modes switch | |

LAM consists of an emitter (6,7, Fig.1), a battery compartment (15,16, Fig.1), windage (9, Fig.1) and elevation (12, Fig.1) adjustment mechanisms, an operating modes switch (17, Fig.1), a remote switch (Fig.2), a clamp (1, Fig.1).

A battery is to be inserted into the battery compartment (16, Fig.1). Battery compartment cap (15, Fig.1) is attached to the body with a rubber band. The battery compartment is sealed with rubber O-ring. A spare O-Ring is included in the delivery set.

Emitter tube output window is closed with a cap (7, Fig.1) with an output aperture. When not in operation, the aperture is closed with a protective rubber cap (8, Fig.1).

LAM is activated by means of the operating modes switch (17, Fig.1) and/or the remote switch (Fig.2). At switching laser radiation on 'laser on' warning indicator 11 lights.

LAM automatically turns off after 30 minutes of being switched in positions C or R. In order to activate LAM after it has automatically turned off, return the switch (17, Fig.1) into OFF position and then switch it to the desired position again.

The switch (17, Fig.1) has the following positions:

	Mode
OFF	Off
C	The aimer is on; Continuous live fire (0.9 mW)
TC	The aimer is on; Continuous live fire; Training mode (0.1 mW)
R	The aimer is on; Remote activation; live fire (0.9 mW)
TR	The aimer is on; Remote activation; live fire; Training mode (0.1 mW)

The remote switch (Fig.2) can be attached to LAM by a connector (3, Fig.2) with a union nut. When not in operation the connector (4, Fig. 1) is covered with a cap. The remote switch key (1, Fig.2) is attached to weapon pivot or grip with velcro tape (2, Fig.3).

LAM is mounted on the Picatinny rail. An optional mount enables mounting LAM on a weapon barrel. This mount's fitting diameter is 15 mm.

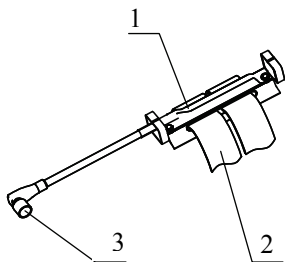

1 — key; 2 — velcro tape; 3 — connector

Fig. 2. Remote switch

3. DELIVERY SET

3.1. Standard delivery set

LAM is supplied in the following assembly:

	Quantity, pcs
LAM 10M IR 3A	1
Remote switch	1
Velcro tape	2
O-Ring	1
Case	1
Manual	1
Battery CR123	1

3.2. Optional parts

LAM can be supplied with a barrel mount.

4. Specifications

	C (R) mode	CT(RT) mode
Laser wavelength	830...860 nm	
Beam divergence	0.5 mrad	
Spot size at 50 meters	25 mm	
Windage and elevation adjustment range	±20 mrad	
Windage and elevation adjustment step	0.5 mrad (50 mm @100m)	
Accuracy of adjustment after 1000 shots	0.1 mrad	
Accuracy of adjustment after 100 re-mountings on a rail	1 mrad	
Laser power (normal / training modes)	0.9 mW	0.1 mW
Illumination distance	1000 m	200 m
Voltage	3 V	
Battery type	CR 123	
Battery life	10 hours	30 hours
Operating temperature range	-40°C...+60°C	
Mount type	MIL-STD-1913	
Dimensions	113x45x32 mm	
Weight	200 g	

5. OPERATION INSTRUCTIONS

5.1. Installing the battery

LAM is powered by a standard Lithium CR123 3V battery.

To install a battery:

- unscrew the battery compartment cap (15, Fig.1),
- insert a battery observing the polarity as marked on the battery compartment,
- check the condition of the O-ring on the body; replace it if worn or torn,
- screw the battery compartment cap back on.

5.2. Mounting LAM on a weapon

LAM is mounted on a Picatinny rail in the following order:.

- loosen screw caps (13, Fig.1),
- align LAM on Picatinny rail,
- fasten the screw caps (13, Fig.1).

Note: The distance between the gas exit nozzles of the rifle and laser beam output window should be as long as possible so that the window would remain clean during shooting.

5.3. Connecting the remote control

To connect the remote switch (Fig.2):

- unscrew the cap of the remote connector (4, Fig.1) and store it in a safe place,
- plug in the remote connector contact (3, Fig.2) observing the key visible on the cable side,
- tighten the union nut,
- attach the remote switch to the weapon pivot or grip with velcro tape (2, Fig.2).

5.4. Adjusting LAM on a weapon

Prior to adjusting LAM which has never been in operation, perform 10 shots in order to stabilize LAM adjustment mechanisms under the influence of shock.

LAM adjustment should be performed after checking the weapon fire capability (with an iron sight) or bringing it to normal fire under the same conditions in the following order:

- zeroing in distance is selected in accordance with fire instructions for a given type of weapon;
- mount LAM on the weapon;
- fix the weapon in the aiming rest and aim it with the help of an iron sight, that is set out in the same way as when checking the weapon fire capability, and at the same point;

- remove protective cap (8, Fig. 1) from emitter tube output window;
- activate LAM in mode C or TC;
- match the center of radiation spot with the aiming mark by means of rotating handwheels of adjustment mechanisms;
- perform test firing with LAM under the same conditions as when checking the weapon fire capability with an iron sight;
- eliminate deviation of the center of impact from the aiming mark. Deviation is measured by adjustment steps: each click of adjustment mechanism corresponds to the shift of radiation spot by 50 mm, when firing at the target situated at a distance of 100 m, i.e. 0.5 mrad;
- fire again after introducing adjustments;
- cover emitter tube output window with protective cap (8, Fig.1).

After adjusted LAM is remounted on the same Picatinny rail of the same weapon new re-adjustment is not required.

When firing at a distance to which the weapon with LAM was zeroed, aiming should be performed by pointing radiation spot at the target. When firing at other distances, aiming should be performed in accordance with the table of exceeding the average bullet trajectories above the line of sight.

6. Maintenance, storage and transportation

6.1. General

LAM is a sophisticated precise optical instrument equipped with electronics. Therefore, it should be handled with due care.

- Never disassemble LAM.
- Keep away from direct sunlight, impacts, dust, moisture, and sharp changes of temperature.
- Do not keep LAM at temperatures higher than 60°C (140°F). Keep away from heating appliances and central heating.
- Do not touch the optical surfaces with fingers. Doing so may damage the anti-reflection coating.
- Avoid shocks and sharp jolts.
- Clean optical surfaces only with professional camera lens cleaning supplies.
- Use soft clean cloth to wipe the exterior of LAM.
- Remove battery when storing for long period of time.
- All repairs must be performed by an authorized service.
- If LAM was exposed to salt water it should be rinsed in fresh water and dried on air at no more than 60°C.

6.2. Storage

To set LAM from combat position into a stowed one:

- turn LAM off (operating modes switch (17, Fig.1) should be set to OFF position);
- cover emitter tube output window with protective cap (8, Fig.1);
- disconnect remote switch (Fig.2) from the weapon, loosen screw caps (13, Fig.1), remove LAM with remote switch from Picatinny rail and place it into the case.

LAM in the original packing should be stored in heated premises within the temperature range from +5 to +40°C, relative humidity not higher than 80 % at temperature +25°C.

Battery should be stored separately from LAM.

When preparing for long-term storage, cover the external metal surfaces of LAM with protective lubricant. Each 4 (four) years old layer of lubricant should be removed and new layer applied.

To remove old layer of lubricant:

- Wipe LAM with clean dry cloth,
- Degrease the metal surfaces of LAM with cloth moistened in benzene,
- Dry LAM in the open air.

Do not touch LAM's metal surfaces with fingers after cleaning.

To apply new layer of lubricant:

- Within two hours from cleaning apply an even 0.2-0.5 mm thick layer of lubricant on metal surfaces with a brush.
- Do not cover plastic parts.

When preparing for a long-term storage LAM just received from manufacturer or from workshop, ensure that actual set is the same as indicated in the Delivery Set section of this manual.

Cases with LAMs should be placed on stands, shelves or in cupboards at dry heated and ventilated premises in accordance with Storage conditions as described in Specifications.

It is unacceptable to keep LAMs on the floor, near stoves or windows that let through direct sunrays.

Presence of acid and alkaline vapor, as well as of other aggressive admixtures in the air in the storage area may cause damage to LAM.

After 4 years of storage, it is necessary to perform thorough inspection of LAMs' functionality.

6.3. Transportation

To prepare LAM for transportation:

- Turn LAM off by turning operating modes switch.
- Cover aimer with protective cap.

- Disconnect the remote switch from the weapon.
- Dismount LAM from Picatinny rail.
- Pack LAM and remote switch into the case.

When packed, LAMs can be transported by any covered means in accordance with storage conditions as described in this manual.

When in operation, LAM is to be transported in its case or mounted on a weapon.

7. TROUBLESHOOTING

Spot shape or size has changed

Emitter objective lens is dirty. Flush emitter lens with fresh water and wipe it with soft cloth.

No radiation when activating LAM with remote switch

Turn the operating modes switch (17, Fig.1) to OFF position and then turn LAM ON again. If this doesn't help, replace the remote switch.

Radiation doesn't stop when remote switch is released

Replace the remote switch.

Moisture in the battery compartment.

Check the O-ring on the battery compartment cover and replace it if necessary.

Shift of zero line when firing

Tighten screw caps (13, Fig.1) on the Picatinny rail.

8. WARRANTY

NEWCON OPTIK warrants this product against defects in material and workmanship for one year from the date of the original date of consumer's purchase, but no more than 18 months from the date of manufacturing. Should your Newcon product prove defective during this period, please bring the product securely packaged in its original container or an equivalent, along with proof of the date of original purchase, to your Newcon Dealer. Newcon will repair (or at its option replace), the product or part thereof, which, on inspection by Newcon, is found to be defective in materials or workmanship.

What This Warranty Does Not Cover:

NEWCON is not responsible for warranty service should the product fail to be properly maintained or fail to function properly as a result of misuse, abuse, improper installation, neglect, damage caused by disasters such as fire, flood, lightning, improper electrical current, or service other than by a NEWCON Authorized Service. Postage, insurance, or shipping costs incurred in presenting your NEWCON product for warranty service are your responsibility. Please include a check or money order made out to NEWCON OPTIK for the amount of \$15.00 to cover shipping and handling. This covers products shipped in USA or Canada only.

9. CUSTOMER SUPPORT

Should you experience any difficulties with your NEWCON OPTIK product, consult the enclosed manual. If the problem remains unresolved, contact our customer support department at +1(416) 663-6963 or toll free at 1-877-368-6666. Our operating hours are 9am-5pm, Monday - Friday, Eastern Standard Time.

At no time should equipment be sent back to Newcon without following the instructions of our technical support department.

NEWCON OPTIK accepts no responsibility for unauthorized returns.

To locate NEWCON Authorized Dealer call:

Tel: +1(416) 663-6963 Fax: +1(416) 663-9065

Email: newconsales@newcon-optik.com

Web: www.newcon-optik.com

Defective products should be shipped to:

From USA only:

2331 Superior Ave. Cleveland, OH 44114

From all other countries:

105 Sparks Ave., Toronto, ON
M2H 2S5, CANADA

10. QUALITY CERTIFICATE

LAM10M IR 3A serial number:

complies with all technical specifications and has passed the inspection.

Date of production: _____

Quality Inspector: _____

Quality Assurance Seal

NEWCON OPTIK™ 2010